

BENEFITS WITH USING XAVITECH PUMPHOLDER

- Absorbs vibrations
- Easy mounting on PCB or other materials
- Electronic or other components can be placed underneath
- Cost effective

MOUNT DRAWING

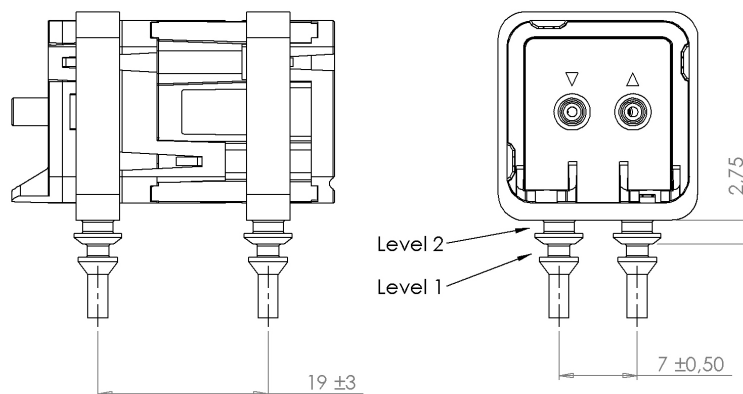

Drill hole 4 x Ø3 mm for level 2 mounting

Drill hole 4 x Ø2mm for level 1 mounting

PUMPHOLDER FOR V200 AND P200 (BLACK AND ORANGE EDITION)

Xavitech can offer a solution that is based on moulded parts in silicon material for pull through quick mount. By press fitting two soft holders, one from each side of the pump, you get 4 soft arrow like pins underneath the pump. These pins you can pull through holes and they will expand on the other side of a PCB and thus create a lock. There are two arrows on each pin so you can mount the pump at two different levels. At level 1 the pump will be elevated 2.75mm and enables you to have electrical components underneath the pump. When pump is mounted on PCB, excessive parts of the pin underneath the PCB can be cut away.

Information furnished is believed to be accurate and reliable. However, Xavitech assumes no responsibility for the consequences of use of such information nor for any infringement of patents or other rights of third parties which may result from its use. No license is granted by implication or otherwise under any patent or patent rights of Xavitech. Specifications mentioned in this publication are subject to change without notice. This publication supersedes and replaces all information previously supplied. Xavitech products are not authorized for use as critical components in life support devices or systems without express written approval of Xavitech.