

LONGER

WT3000-1JA Micro Gear Pump Drive Operating Manual

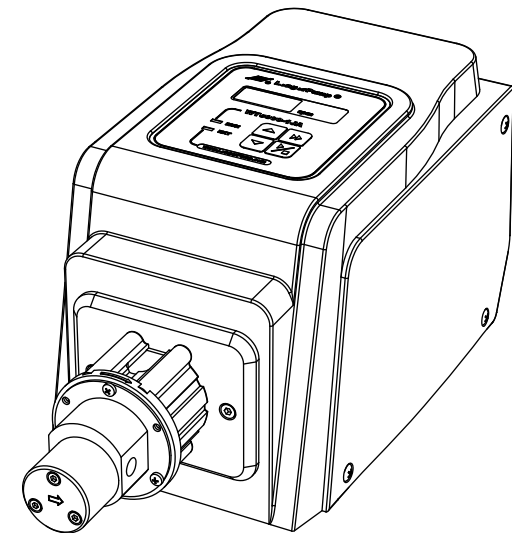

LONGER

Baoding Longer Precision Pump Co., Ltd.

Add: 3rd/4th Floor, Building 6B, University Science Park
Baoding National, High - Tech Industrial Development Zone
Baoding, Hebei, China 071051
Tel: 86 - 312 - 3110087 3138553
Fax: 86 - 312 - 3168553
E - mail: longer@longerpump.com
Http://www.longerpump.com

WT3000-1JA Gear Pump Drive

Baoding Longer Precision Pump Co.,Ltd.

Micro Gear Pump Drive Operating Manual

 **Important Information:**
Please read operating manual carefully before operation.

-  **Warning:**
- To prevent damage to pump, do not run the pump dry.
 - If the power line or the plug are worn or damaged please pull out the plug (Hold the plug not the power line when pulling out).
 - Please shut down the power supply and pull out the plug when you think the pump needs to be maintained or repaired.
 - Shut down the power supply of the pump when connecting to external control equipment.
 - The International Protection rating of this pump is IP31. Do not let liquid enter this pump drive.

Warranty:

- The warranty period of this product is one year. If repair or adjustment is necessary within the warranty period, the problem will be corrected at no charge if it is not due to misuse or abuse on your part, as determined by the manufacturer. Repair costs outside the warranty period, or those resulting from product misuse or abuse, may be invoiced to you.
- Contact Longer Company or Longer's dealers before returning pump to repair.
- Adopt original carton or reliable package when returning pump to repair.
- Write a note on detailed description of failure phenomena and contact information and put this note along with pump before returning pump to repair.

Table of Contents

Introduction	1
Operation Panel	2
Basic Operation	2
Changing the Pump Head	3
Acceptable Pump Head	3
External Control Function	3
Communication Control Mode	4
Analog Signal Control Mode	4
Footswitch	5
Maintenance	5
Technical Specifications	6

Instruction

WT3000-1JA micro gear pump accepts MG204, MG209, MG213 pump heads. It has features of wide flow rates range, low pulse and big pressure. The pump delivers flow rates from 85.7 to 2571.4 ml/min. It adopts DC brushless motor which has characters of high efficiency and free maintenance.

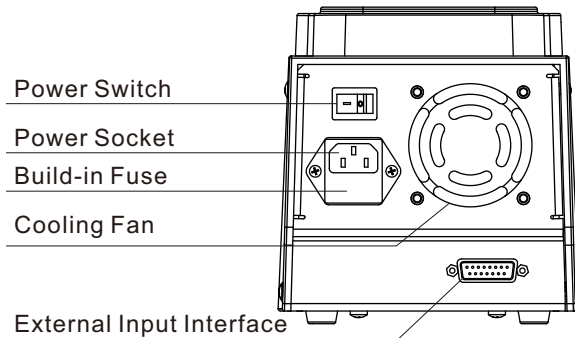
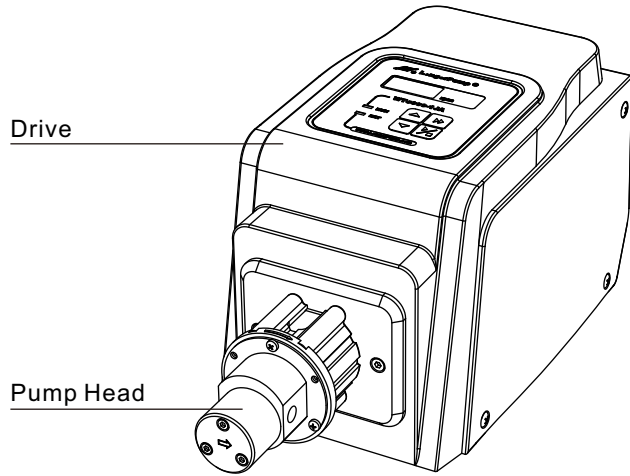

Reference:

For detail information about external control function please see page 10.

Operation Panel

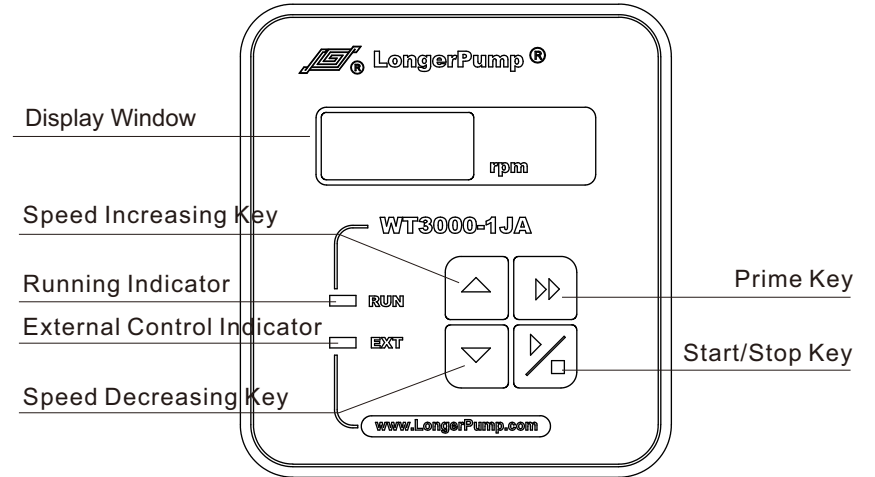

Basic Operation

- **Start/Stop Key**
Press the Start/Stop Key to switch the start and stop of the pump.
- **Speed Increasing Key**
Press Speed Increasing Key one time, the speed of the pump increases one turn. Press Speed Increasing Key continuously, the speed of the pump increases rapidly up to 3000 rpm.
- **Speed Decreasing Key**
Press Speed Decreasing Key one time, the speed of the pump decreases one turn. Press Speed Decreasing Key continuously, the speed of the pump decreases rapidly until 300 rpm.
- **Prime Key**
Press Prime Key the pump runs at the speed of 3000 rpm and the LED displays "---" for fast emptying, filling and rinsing. Press Prime Key again the pump returns to previous state.

Changing the Pump Head

The pump head has been installed on drive before leaving the factory. Please follow below procedure when changing a new pump head is needed.

1. Loose the 3 pieces M3 tightening screws which connecting the pump head and the pump head support. Take down the pump head.
2. Tighten the 3 pieces M3 screws to connect the new pump head and the pump head support.
3. For detailed method please refer to pump head operating manual.

 Shut off the power supply before changing a new pump head.

Acceptable Pump Head

Different pump heads have different flow rates range. Please see below:

❖ Pump Head and Flow Rates Table (Pressure: Normal)

Acceptable Pump Heads	Part Number	Flow Rates (mL/min) 300-3000(rpm)
MG204	050501A	85.7-857.1
MG209	050502A	171.4-1714.3
MG213	050503A	

External Control Function:

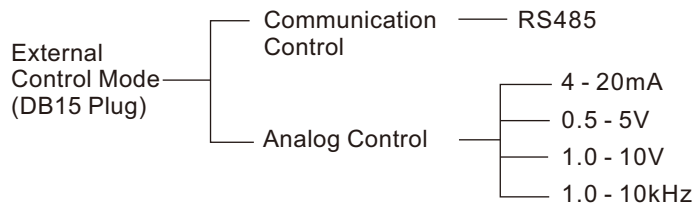

- Communication Control Mode

Pump can provide RS485 communication module (see figure 1) to connect upper machine (computer, PLC, SCM). Customer can ask for communication protocol from Longer Company.

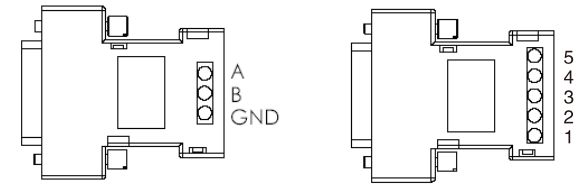



Figure 1: Communication Module

Figure 2: External Control Module

- Analog signal control mode

In external control mode, put 'Internal **【Control/External Control】**' switch to 'External Control' position. Connect external control module with pump according to pin defined as following.

 Note: According to actual needs, 5 kind of external control modules require to be separately order.

Terminals of external control module are defined as following

- 1#: Common input end in 4-20mA, 0.5-5V and 1-10V external control module to control speed of pump.
- 2#: Input end of start/stop of external control. Pump runs during open circuit or inputting low TTL; pump stops during inputting high TTL. (Start/Stop signal is opto-isolated input mode)
- 3#: not available
- 4#: Common end of analog input in 4-20mA, 0.5-5V and 1-10V external control module to control speed of pump.
- 5#: Common end of input signal in 4-20mA, 0.5-5V and 1-10V external control module; common end of frequency input in 1-10kHz external control module.

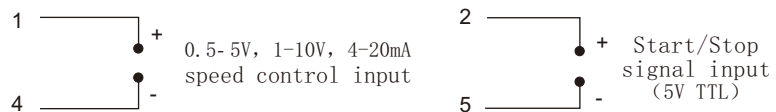

0 - 5V, 0 - 10V, 4 - 20mA External Control Module Wiring Diagram

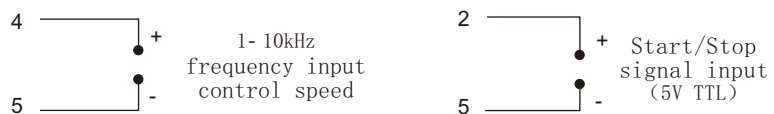

Pulse Input External Control Module Wiring Diagram

Footswitch

Control the start/stop of the pump through the external control interface.

Maintenance

Keep the surface of drive and pump head clean and dry to prolong the service life of the drive and the pump head.

To prevent damage to pump, do not run the pump dry.

Technical Specifications

Flow Rates	85.7-2571.4 (mL/min)
Speed	300-3000 (rpm)
Speed Accuracy	1.0%
Speed Resolution	1 rpm
Display	Four digital LED display running status
External Input Control	Speed control (4-20mA, 0.5-5V, 1.0-10V, 1.0-10kHz corresponding to 300 to 3000 rpm, start/stop control (5V TTL)
Communication	RS485
Acceptable Liquid	Liquid containing particles smaller than 10µm.
Acceptable Liquid Temperature	PTFE - 45- 50 PEEK - 45- 120
Max. Outlet Pressure (Pumping Medium: Water)	MG204: 0.8MPa MG209: 0.8MPa MG213: 0.3MPa
Acceptable Liquid Viscosity	≤200cst
Power Supply	AC176-264V/90-130V, 50Hz/60Hz
Power Consumption	≤150W
Operation Conditions	Temperature 0 to 40℃, Relative Humidity <90% (No dew)
Drive Dimensions (L×W×H)	232×142×149 (mm)
Drive Weight	2.83kg
IP Rating	IP31

